

REVISIONS		
REV	DESCRIPTION	APPROVED

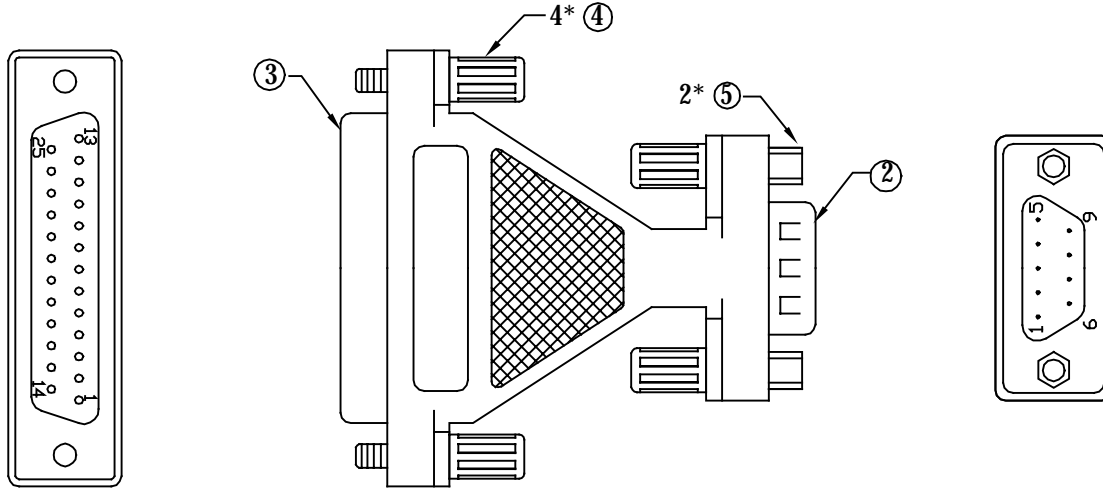

A  
FEMALE

B  
MALE

PIN		OUTS	
A	B	A	B
DB 25 FEMALE	DB 9 MALE	DB 25 FEMALE	DB 9 MALE
8	1	1	1
3	2	2	2
2	3	3	3
20	4	4	4
7	5	5	5
6	6	6	6
4	7	7	7
5	8	8	8
22	9	9	9
Shell	Shell	Shell	Shell

NOTES:

- 1.MOLDED CONNECTOR END REQUIREMENTS:
- A.INNER MOLD USING PE
- B.ALUMINUM FOIL WRAP TO CONNECTOR
- C.PVC - 45P PLATINUM GRAY

INSULATION: UPON 1M ohm AND 1M ohm ELECTRIC CONDUCTION:INSIDE 1.5K ohm			
ITEMNO	PART NAMES	QTY	REMARK
5	(SCREW)NUT:4.75*6mm NICKEL-PLATING	2PCS	
4	THUMBSCREW: MALE 4*22mm NICKEL-PLATING	4PCS	
3	CONNECTOR:DB25P FEMALE NICKEL-PLATING, INSULATOR COLOR:BLUE	1PCS	
2	CONNECTOR:DB9P MALE NICKEL-PLATING, INSULATOR COLOR:BLUE	1PCS	
1	CABLE:JUMPER 26AWG OR 28AWG	10PCS	

	PRODUCT	DB9P MALE TO DB25P FEMALE ADAPTER	CUSTOMER		DRAWN	Hvon .w	 THREE ANGLE PROJECTION
	CUS,NO	313	VERSION		CHECKED	Jackson Cang	
	DR,NO	SD313	DRAWN DATE	OCT.10,2000	APPROVERD	Jonny Chuang	