

REVISIONS		
REV	DESCRIPTION	APPROVED

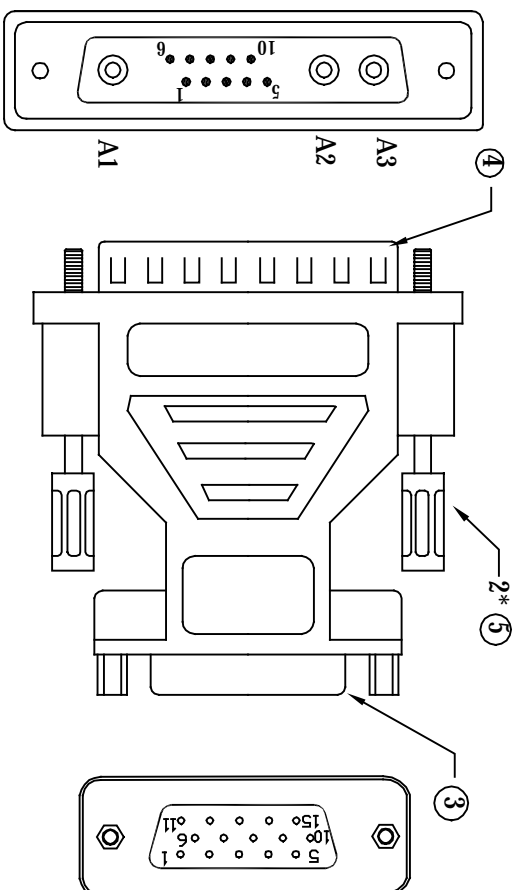

13W3 M

HD15F

NOTES:
 1.MOLDED CONNECTOR END REQUIREMENTS:
 A:INNER MOLD USING PE
 B:COPPER FOIL WRAP AND 360° SOLDER TO CONNECTOR
 C:PVC - 45P PLATINUM GRAY

P1	WIRE COLOR	P2
A1(+)	COAX CENTER	1
A1(-)	COAX SHIELD	6
A2(+)	COAX CENTER	2
A2(-)	COAX SHIELD	7
A3(+)	COAX CENTER	3
A3(-)	COAX SHIELD	8
5	COAX CENTER	13
10	COAX SHIELD	10
3	JUMPER	
4		
SHELL	SHIELD	SHELL

ITEM NO	DESCRIPTION	QTY	REMARK
1	CABLE:JUMPER 28AWG	1PCS	
2	CABLE:COAXIAL 24AWG	4PCS	
3	CONNECTOR:HD15P FEMALE NICKEL-PLATING, INSULATOR COLOR:BLACK RIVETING SCREW NUT	1PCS	
4	CONNECTOR:13W3 MALE NICKEL-PLATING, INSULATOR COLOR:BLACK	1PCS	
5	THUMBSCREW: MALE 4*32mm NICKEL-PLATING	2PCS	

INSULATION: UPON 1M ohm AND 1M ohm ELECTRIC CONDUCTION INSIDE 1.5K ohm

ITEM NO	PART	NAMES	QTY	REMARK

ComputerCableStore
 Discount Computer Cables and Connectivity Solutions

PRODUCT	HD15P FEMALE TO 13W3 MALE ADAPTER	CUSTOMER	DRAWN	HYON .W	THREE ANGLE PROJECTION
CUS,NO	341	VERSION	CHECKED	Jackson Cang	
DR,NO	SD341	DRAWN DATE	APPROVED	Jonny Chuang	